

Cable Management for AC Stand

Installation Instructions

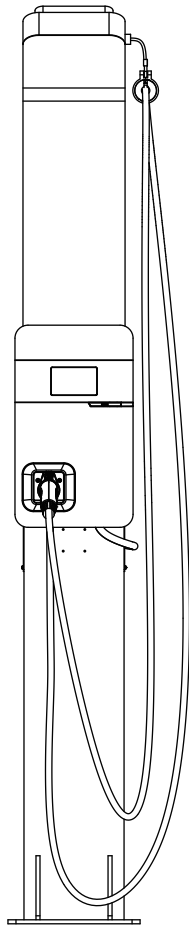

support@turnongreen.com

Copyright ©, TURNONGREEN
TURNONGREEN reserves the right to update the manual without any notice.

1.Package list

STEP 1

Unpack

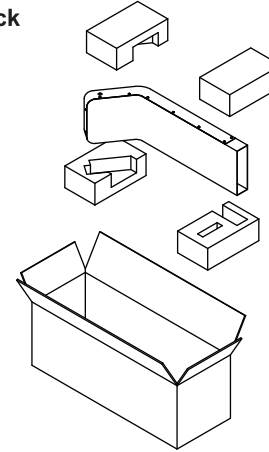

Item	Description	QTY.	Remark
1	Cable Management	1	
2	Accessory	1	
2.1	User manual	1	
2.2	T25	1	
2.3	M8x20L	2	
2.4	Cable clip	1	
2.5	Plastic-Ø18	1	
2.6	Plastic-Ø22	1	

STEP 2

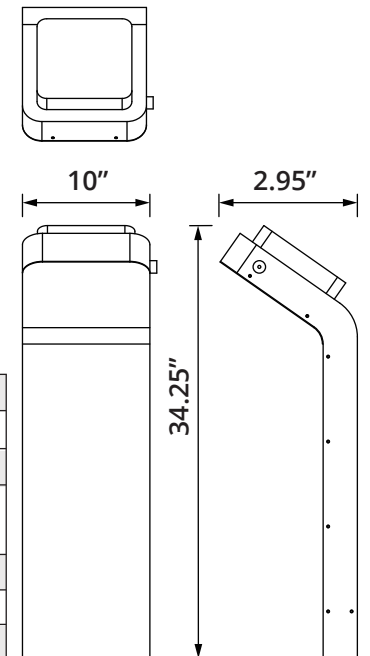

Product Specification

Model Name	KITCONSAXPH01-RW
Dimensions (inches)	L255"xW10.82"xH34.25"
Weight (lbs)	27.55
Cable Outer diameter (mm)	.7" & .86"
Initial pull (kgf)	2~3
Stroke (M)	2.5
Wire diameter (inch)	.11"

2. Install cable management

STEP 1

Install Cable Management.

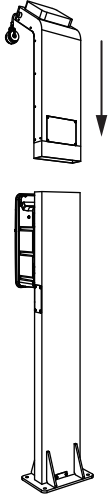

STEP 2

Remove 4 M4X8L screws from the back cover.

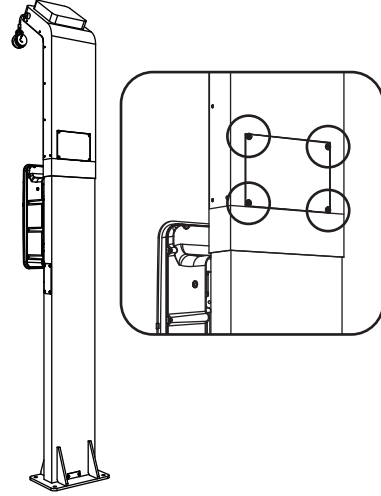

STEP 3

Fasten 2~M8X20L.

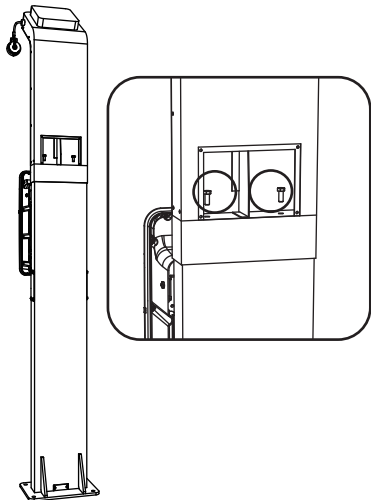

STEP 4

Screw the back cover.

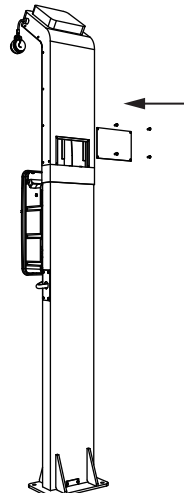

3. Install the slinger ring

STEP 1

Pull down the slinger ring to the proper height.(need to pause the steel rope to stop)

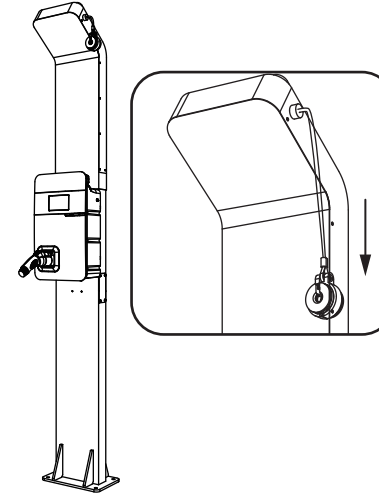

STEP 2

1.Disassemble and select plastic 18 or 22 by referring the cable outer diameter.

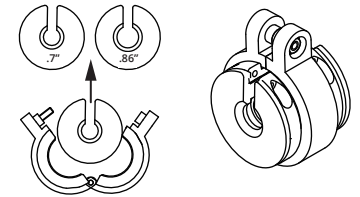

2.Lock the slinger ring 8' away from the outlet of the cable gun.

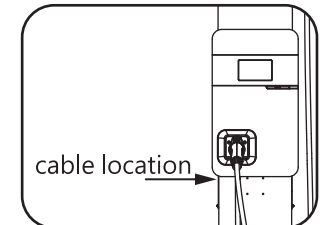

STEP 3

Lock the slinger ring's cover inside then pull once to let the steel rope back.

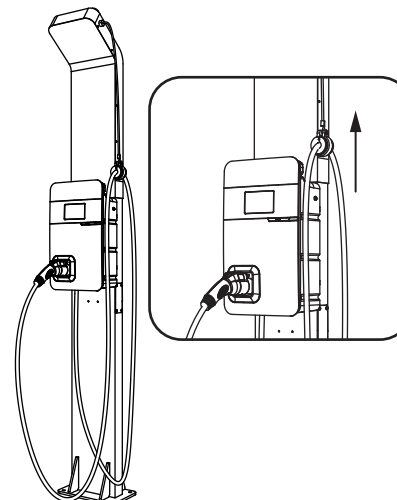

STEP 4

Insert EV plug back to the holder.

